

# Thomson PC-Series™ Precision Linear Actuator

Installation Manual

Edition 2025-11



## Version History

<b>Edition</b>	<b>Reason for revision</b>
2014-01	First edition
2023-07	PC45 changed to PC40 in table T.6.1.1 and new lit code (was DW110697-GB)
2024-03	Table reference on page 21 in point 13 changed to T5.5.3.
2025-11	Corrected tightening torques in 4.11.2, paragraph 3 and updated front and back cover logotypes and layout.

## Warranty

The Thomson PC-Series™ is warranted to be free from defects in materials and workmanship for a period of twelve (12) months from date of delivery. The application of this product is the responsibility of the buyer and Thomson makes no representation or warranty as to the suitability of the product for any particular use or purpose. For a copy of the entire warranty for this product that is contained in our standard terms and conditions of sale, please go to [http://www.thomsonlinear.com/website/com/eng/support/terms\\_and\\_conditions.php](http://www.thomsonlinear.com/website/com/eng/support/terms_and_conditions.php).

## Disclaimer

**Technical changes to improve the performance of the equipment may be made without prior notice!**

All rights reserved. No part of this work may be reproduced in any form (by printing, photocopying, microfilm or any other method) or processed, copied or distributed by electronic means without the written permission of Thomson.

**Contents**

<b>1. General</b> .....	<b>4</b>
1.1 About this manual.....	4
1.2 Target group .....	4
1.3 Symbols used.....	4
1.4 Transport and storage .....	4
1.5 Disposal.....	4
1.6 Support.....	4
<b>2. Safety</b> <b>5</b>	
2.1 Safety notes .....	5
<b>3. Standards</b> .....	<b>5</b>
3.1 EC Declaration of conformity.....	5
<b>4. Installation</b> .....	<b>6</b>
4.1 Name plate .....	6
4.2 Terminology .....	6
4.3 Operation environment .....	6
4.4 General mounting guidelines.....	7
4.5 Mounting of the unit using the mounting holes.....	8
4.6 Mounting of the unit using the extension tube rod end.....	9
4.7 Mounting of the unit using the mounting accessories .....	10
4.8 Mounting of sensor brackets .....	15
4.9 Mounting of sensors in the sensor brackets.....	15
4.10 Motor installation on inline style actuators without RediMount system .....	15
4.11 Motor installation on actuators with RediMount system .....	15
<b>5. Service and maintenance</b> .....	<b>18</b>
5.1 General.....	18
5.2 Cleaning .....	18
5.3 Lubrication.....	18
5.4 Replacement of coupling on inline models with RediMount flange .....	19
5.5 Replacement of belt gear timing belt.....	20
<b>6. Technical specifications</b> .....	<b>22</b>
6.1 Technical data .....	22
6.2 Type designation key.....	23
6.3 Screw tightening torque.....	23

## 1. General

### 1.1 About this manual

This manual describes how to install the Thomson PC-Series precision linear actuator mechanically and electrically. It also contains, among other things:

- technical data
- dimensional drawings
- type designation key.

It is important to carefully read this manual before installing the actuator and to have the correct qualifications needed to perform the installation.

### 1.2 Target group

This manual addresses qualified mechanical and electrical personnel.

### 1.3 Symbols used



This symbol is shown to highlight a general warning, general instruction or as a warning for a mechanical hazard.

### 1.4 Transport and storage

The actuator may only be transported and stored in the original packaging supplied by Thomson. The temperature during transportation and storage must be between -40 to +85 °C (-40 to +185 °F). Avoid shocks to the package. If the package is damaged, check the actuator for visible damage and notify the carrier, and if appropriate also Thomson.

### 1.5 Disposal

Where required by law, used packaging and actuators are taken back by Thomson for professional disposal if the transportation cost is taken over by the sender. Please contact Thomson for information on where to ship it.

### 1.6 Support

In case you need technical support or any information related to this product, please contact the nearest Thomson Service Center. See the back of this manual. You can also visit [www.thomsonlinear.com](http://www.thomsonlinear.com) for information on this product and how to get in touch with us.

## 2. Safety

### 2.1 Safety notes



- Only properly qualified personnel are permitted to perform mechanical and electrical installation, service or maintenance on this product. Properly qualified personnel are familiar with mechanical or electrical installation work and that have the appropriate qualifications for their jobs.
- Read this manual and any other available documentation before working on the equipment that the actuator is or shall be a part of.
- Keep strictly to the data in this manual and on the name plate on the actuator and never exceed the performance limits stated herein.
- Never work on the actuator or its installation with the power on.
- Never unplug any cables or connectors during operation or with power on.
- Immediately stop using the actuator if it seems faulty or broken in any way and notify an appropriate person so that corrective actions can be taken.
- Never try to open the actuator as that will compromise the sealing and the function of the actuator. There are no serviceable components inside.
- Grease may be present on the extension tube. Contact is non-hazardous. Film should not be removed.

## 3. Standards

### 3.1 EC Declaration of conformity

We, Tollo Linear AB declare that this products corresponds with the directive 2006/42/EC annex 2.1.B, RoHS II directive 2011/65/EU, WEEE directive 2002/96/EC, low voltage directive 2006/95/EC (EN60204-1:2006+A1:2009) and also with the directive of electromagnetic compatibility 2004/108/EC (EN55014-1:2006+A1:2009, EN61000-6-3:2007, EN61000-3-2:2006+A2:2009, 61000-3-3:2008) and that the standard EN ISO 12100:2010, Safety of machinery, have been applied.

**Thomson Precision Linear Actuator**

Product

**PC**

Description

Can be used when the machine or the system, which it shall be, a part of is in accordance with the demands in the EEC Machinery Directive and/or other relevant regulations.

**Kristianstad 2014-04-14**

Date

**Anders Trygg**

Name

**Business Unit Manager**

Title

Signature

## 4. Installation

### 4.1 Name plate

The name plate can be found on the actuator cover tube. It will tell you which model of actuator you have and its basic performance data. Please study the name plate to see what type of actuator you have before starting any installation or service on the actuator. If you need any assistance from Thomson, please tell us the manufacturing date and the designation of the actuator(s) in question.

<b>THOMSON™</b> Tollo Linear AB Sweden		<b>PC32</b>	
DESIGNATION PC32LX367B04-0100XM1		MOVE/SHAFT/REV. 4MM	STROKE 100mm
MAN. DATE 2014-03-14	PROT. IP65	SERIAL No. 14.5654	
 FOLLOW INSTRUCTIONS IN MANUAL. DO NOT DISASSEMBLE ALWAYS USE END OF STROKE LIMIT SWITCHES. DO NOT RUN INTO ENDSTOP.			

### 4.2 Terminology

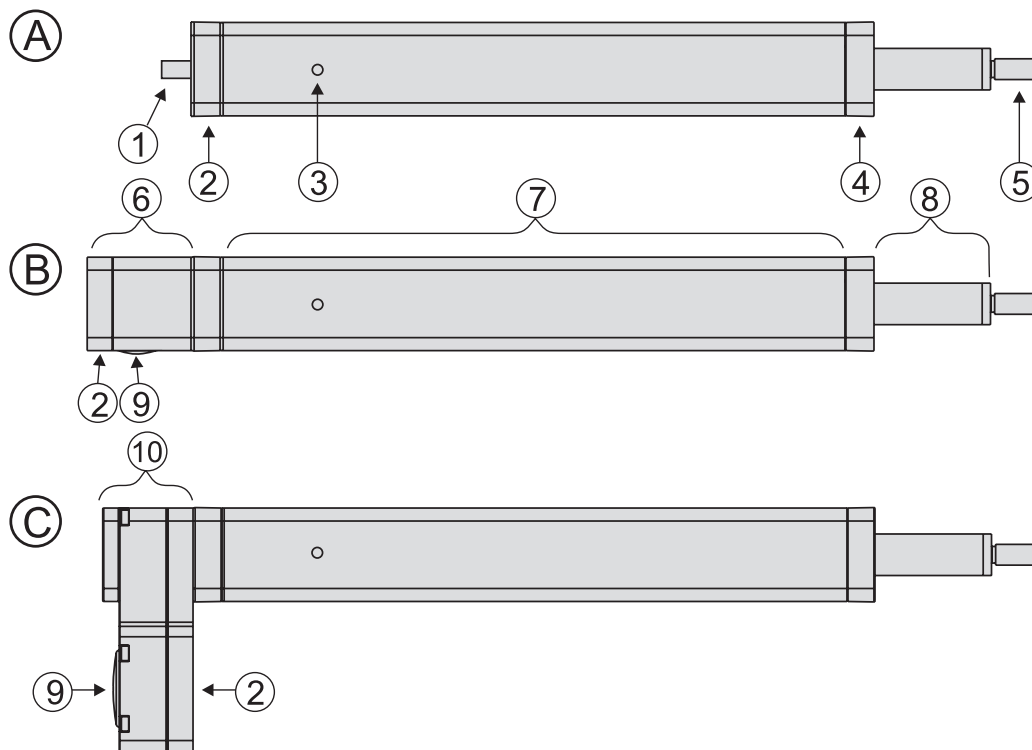

- A. inline style PC-Series actuator without RediMount system
- B. inline style PC-Series actuator with RediMount system
- C. parallel style PC-Series actuator with belt gear and RediMount system

1. input shaft	5. front adaptor	9. access plug for coupling clamping element
2. motor flange plate	6. RediMount system	10. belt gear with Redimount system
3. grease port	7. cover tube	
4. front plate	8. extension tube	

4.3 Operation environment



Min. -20° C



Max. +70° C



IP65

Operation temperature range is between -20 to +70° Celcius. Protection degree against the ingress of water and particles is IP65.

4.4 General mounting guidelines

The unit can be mounted in any direction but do not mount the actuator so that the cover tube is subjected to any bending or twisting forces.

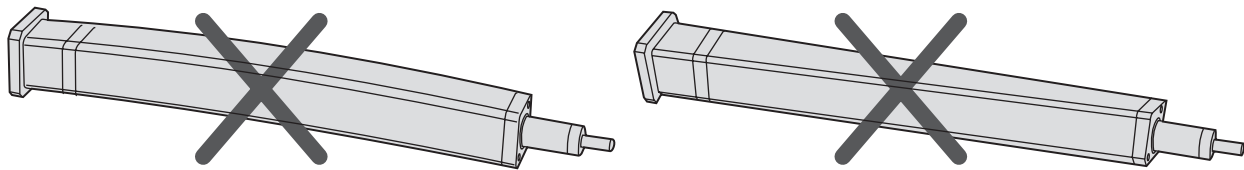

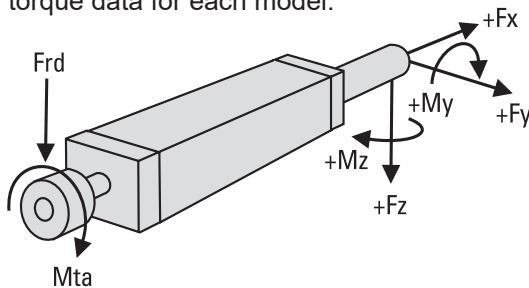

Mount actuator so that the the maximum permissible load and load torques for the input shaft or the extension tube never are exceeded during stand still or operation. See table T6.1.1 for load and load torque data for each model.

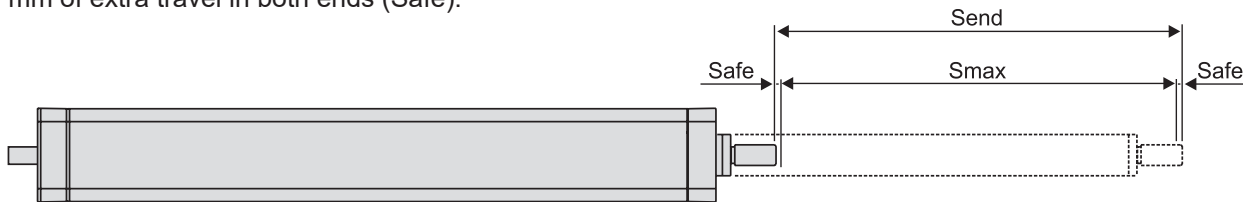

Make sure to install the actuator so that the extension tube never runs in to the mechanical end stops. The distance between the mechanical end stops (Send) are the ordering stroke (Smax) plus 2.5 (± 0.5) mm of extra travel in both ends (Safe).



 **Warning!** Do not hold the extension tube while the unit is energized.

 **Warning!** The extension tube is not self holding - in a vertical application a brake is required to hold the load at stand still. If it is removed the extension tube may start moving with the possible risk of injury to people or damage to the equipment.

 **Warning!** Never run in to the mechanical ends of the unit.

## 4.5 Mounting of the unit using the mounting holes

All PC-Series actuators have mounting holes in the front plate while the parallel style also have mounting holes in the rear plate on the belt gear. The mounting holes can be used to attach the unit to the support or to the mounting accessories designed for the purpose (see point 4.7). Make sure to follow the general mounting guidelines (see point 4.4) when using the mounting holes.

### 4.5.1 Mounting of the unit using the front plate mounting holes

See below drawings for hole pattern, size and thread depth of the front mounting holes. Note that the mounting holes on PC32 and PC40 has a 14 mm long unthreaded part before the thread starts.

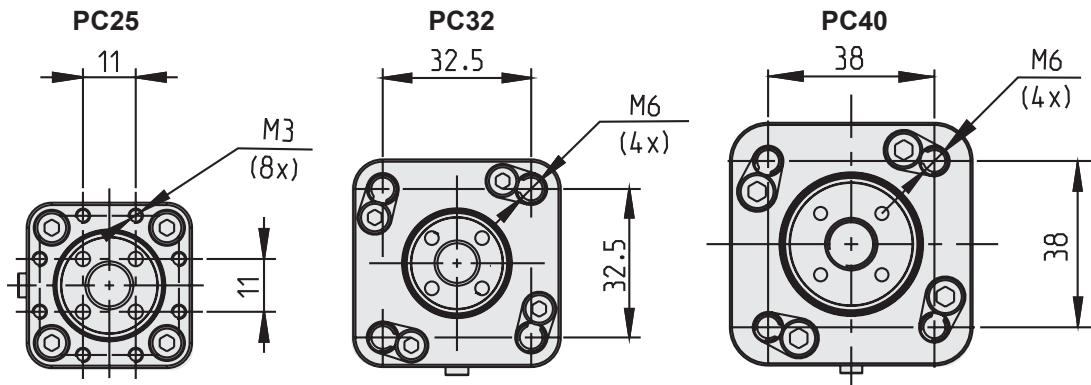

	Mounting hole size	Total mounting hole depth [mm]	Outer unthreaded depth [mm]	Inner threaded depth [mm]
PC25	M3	14	0	14
PC32	M6	44	14	30
PC40	M6	44	14	30

### 4.5.2 Mounting of the unit using the rear plate mounting holes on parallel style units

See below drawings for hole pattern, size and thread depth of the rear mounting holes.

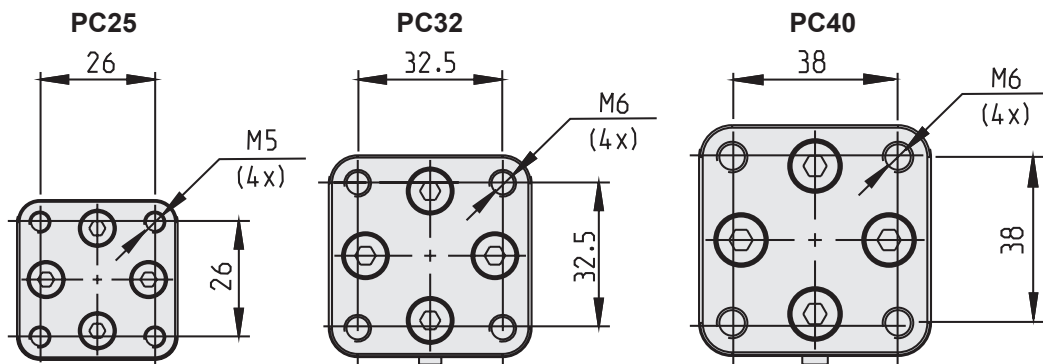

	Mounting hole size	Mounting hole thread depth [mm]
PC25	M5	8
PC32	M6	8
PC40	M6	8

## 4.6 Mounting of the unit using the extension tube rod end

The extension tube rod end always have either a male or a female threaded rod end mounted from the factory. A spherical joint (see point 4.7.1) or a clevis (see point 4.7.2) can also be mounted to the male threaded rod end, either from factory or by the customer as a separate part in which case you must follow the below instructions plus the instructions for the spherical joint or the clevis. The designation on the name plate and the ordering key (table T6.2.1) will help you determine which rod end accessory the unit is equipped with. If a spherical joint or a clevis is delivered as a separate part you have to determine which of them it is (see part number on the accessory packaging labels) and the actuator model (see the name plate) and follow the appropriate instruction to mount it (see point 4.7.1 or 4.7.2). If in doubt, contact customer support

### 1. Male threaded rod end

	A	B
PC25	22	M10 × 1.25
PC32	22	M10 × 1.25
PC40	26	M12 × 1.25

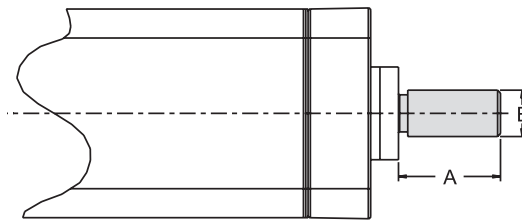

### 2. Female threaded rod end

	A	B
PC25	15	M10 × 1.25
PC32	15	M10 × 1.25
PC40	18	M12 × 1.25

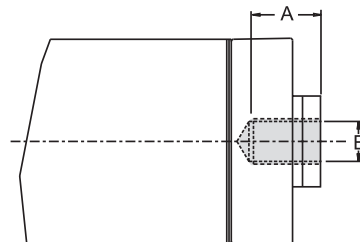

The extension tube can handle some side load (see table T6.1.1 for load and load torque data for each model) but in order to improve overall performance and life it is good practice to follow the below points even if the side loads do not exceed the maximum permitted levels.

- Make sure the extension tube travel in a straight line in relation to the cover tube.
- Try to align the center of the load with the extension tube travel center.
- Avoid side loads altogether if possible.

## 4.7 Mounting of the unit using the mounting accessories

The unit can be shipped with mounting accessories mounted from the factory, in this case the designation on the name plate and the ordering key (table T6.2.1) will help you determine which accessory the unit is equipped with and which mounting instruction below to follow. Some of these mounting accessories can also be ordered as separate parts and be mounted to the actuator by the customer. In this case you have to determine which accessories (see part number on the accessory packaging labels) and actuator model (see the name plate) you have and select appropriate instructions. If in doubt, contact customer support.

### 4.7.1 Spherical joint

To be able to mount a spherical joint the extension tube must be equipped with a male threaded rod end. Screw the joint on to the rod end and secure it with the jam nut. Use a solid pin to connect the joint to the load. Keep in mind that any play between the pin and the joint may affect the accuracy.

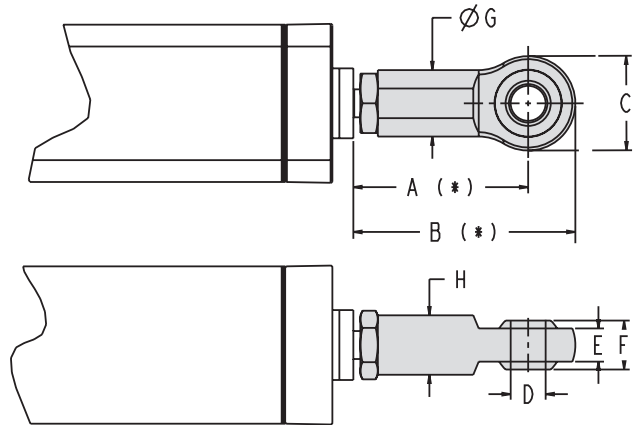

	A (REF.) *	B (REF.) *	C	D (Ø)	E (H9)	F	G	H	p/n
PC25	50	64	28	10	10.5	14	19	17	D607 406
PC32	50	64	28	10	10.5	14	19	17	D607 407
PC40	58	74	32	12	12	16	22	19	D607 408

\* assuming 2 mm gap from jam nut to shoulder.

### 4.7.2 Front clevis

To be able to mount a separate front clevis the extension tube must be equipped with a male threaded rod end. Screw the clevis on to the rod end and secure it with the jam nut.

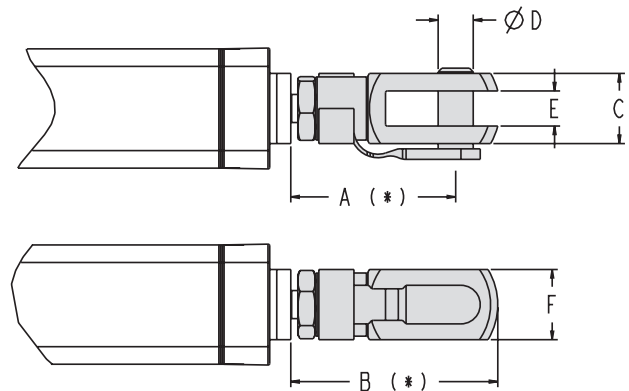

	A (REF.) *	B (REF.) *	C	D (Ø h11)	E (B11)	F	p/n
PC25	47	59	20	10	10	20	D607 409
PC32	47	59	20	10	10	20	D607 410
PC40	56	70	24	12	12	24	D607 411

\* assuming 2 mm gap from jam nut to shoulder.

**4.7.3 Rear clevis - for PC25 parallel style models**

The rear clevis is mounted to the rear plate of the belt gear housing. All necessary screws to attach it to the actuator are included. Make sure to tighten all four screws according to table T6.3.1. Use a solid pin to connect the joint to the load. Keep in mind that any play between the pin and the joint may affect the accuracy.

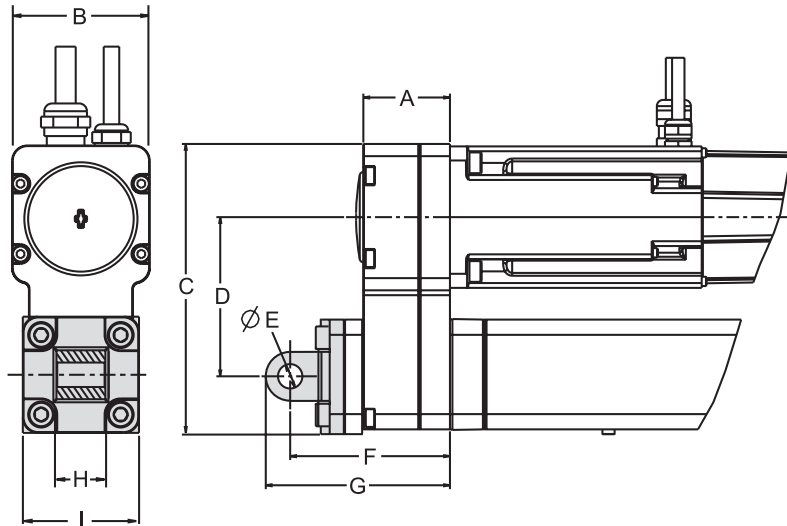

	A	B	C	D	E (Ø H9)	F	G	H (h14)	I	p/n
PC25	36	45	92	51	8	64	72	16	38	D607 412

**4.7.4 Rear clevis - for PC32 and PC40 parallel style models**

The rear clevis is mounted to the rear plate of the belt gear housing. All necessary screws to attach it to the actuator are included. Make sure to tighten all four screws according to table T6.3.1. Use a solid pin to connect the joint to the load. Keep in mind that any play between the pin and the joint may affect the accuracy.

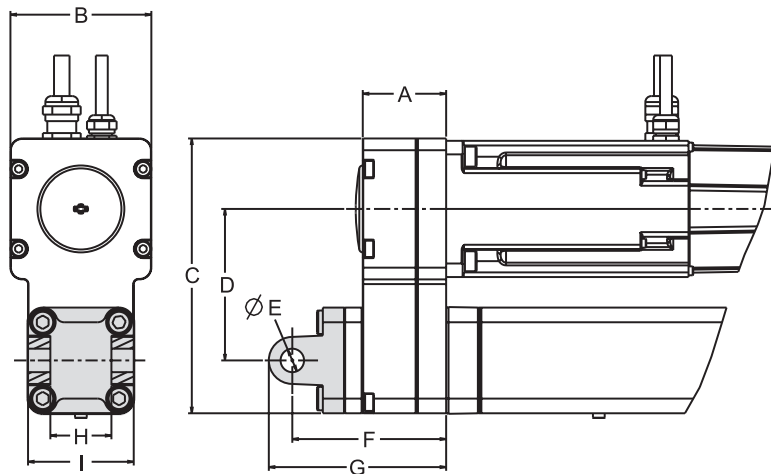

	A	B	C	D	E (Ø H9)	F	G	H (H14)	I	p/n
PC32	35,5	60	117	64,5	10	65,5	75,5	26	45	D607 413
PC40	42,5	70	136	73,5	12	75,5	88	28	52	D607 414

## 4.7.5 Front mounting plate

The front mounting plate is mounted to the front plate of the cover tube. All necessary screws to attach it to the actuator is included. Make sure to tighten all four screws according to table T6.3.1.

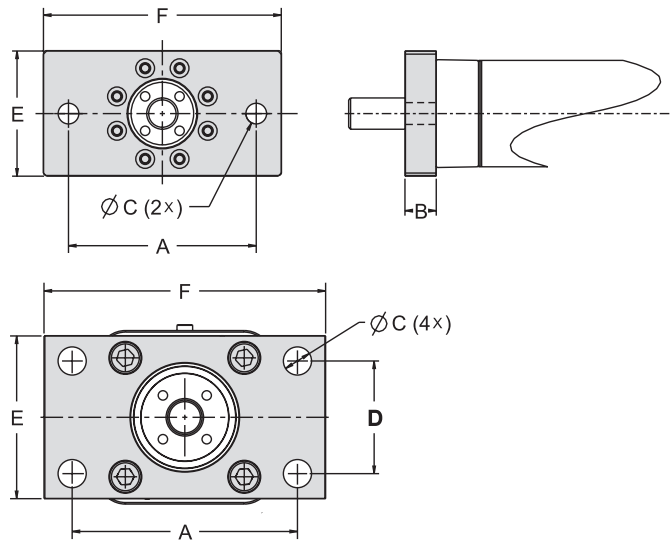

	A	B	C	D	E	F	p/n
PC25	60	10	6.6 (2x)	-	40	76	D607 415
PC32	64	10	7.0 (4x)	32	45	80	D607 416
PC40	72	10	9.0 (4x)	36	52	90	D607 417

## 4.7.6 Foot mount for inline style models

The foot mount consists of a front and rear bracket. All necessary screws to attach it to the actuator is included. Make sure to tighten all attachment screws according to table T6.3.1.

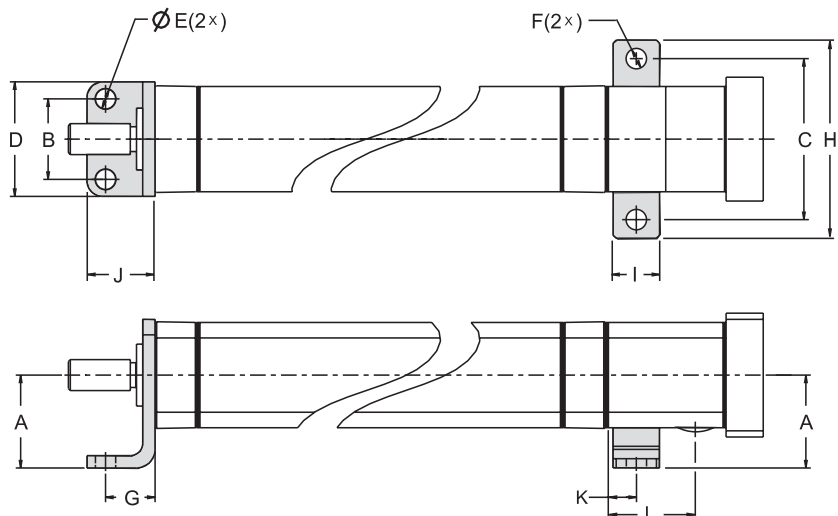

	A (JS15)	B	C	D	E	F	G	H	I	J	K	L	p/n
PC25	30	26	52	37	6.6	6.6	16	64	15	22	8.5	28	D607 418
PC32	32	32	65	45	6.6	6.6	24	78	15	35	8.5	35	D607 419
PC40	36	36	70	52	9	6.6	28	85	15	36	8.5	38.5	D607 420

**4.7.7 Foot mount for parallel style models**

The foot mount consists of a front and rear bracket. All necessary screws to attach it to the actuator is included. Make sure to tighten all attachment screws according to table T6.3.1.

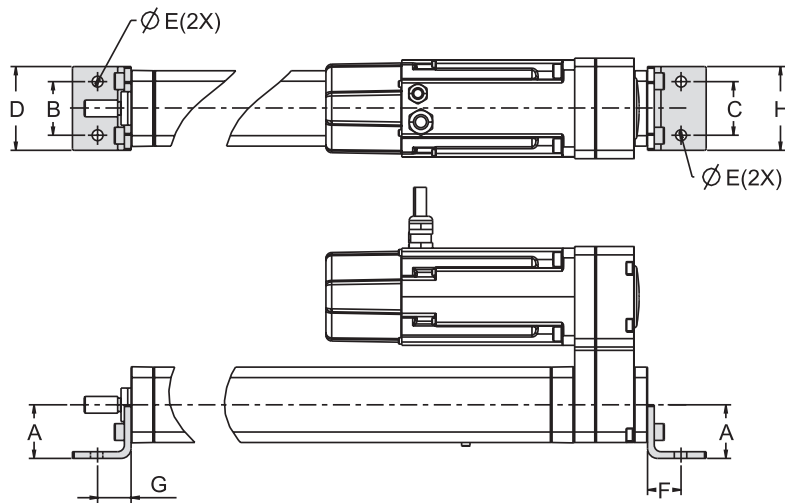

	A	B	C	D	E	F	G	H	p/n
PC25	30	26	26	37	6,6	16	16	40	D607 421
PC32	32	32	32	45	6,6	24	24	45	D607 422
PC40	36	36	52	52	9	28	28	52	D607 423

**4.7.8 Fixed front trunnion**

The fixed front trunnion consist of a plate with two shafts. All necessary screws to attach it to the actuator is included. Make sure to tighten all attachment screws according to table T6.3.1. Contact your local bearing supplier for advice on suitable bearings between the trunnion pins and the support.

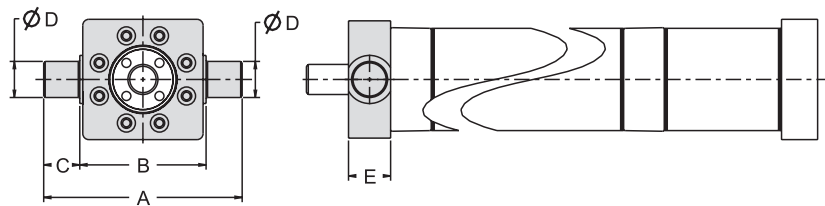

	A (REF.)	B (h14)	C (h14)	D (e9)	E	p/n
PC25	66	42	12	12	14	D607 424
PC32	74	50	12	12	14	D607 425
PC40	95	63	16	16	19	D607 426

## 4.7.9 Fixed rear trunnion for parallel style models

The fixed rear trunnion consist of a plate with two shafts. All necessary screws are to attach it to the actuator is included. Make sure to tighten all attachment screws according to table T6.3.1. Contact your local bearing supplier for advice on suitable bearings between the trunnion pins and the support.

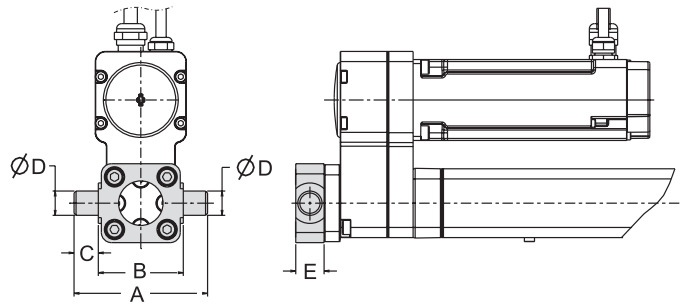

	A (REF.)	B (h14)	C (h14)	D (e9)	E	p/n
PC25	66	42	12	12	14	D607 433
PC32	74	50	12	12	14	D607 434
PC40	95	63	16	16	19	D607 435

## 4.7.10 Movable cover tube trunnion

The movable trunnion consists of two clamp units that are put around the profile of the unit at desired position and joined and locked in place by the lock screws. Make sure to tighten the lock screws according to table T6.3.1. Contact your local bearing supplier for advice on suitable bearings between the trunnion pins and the support.

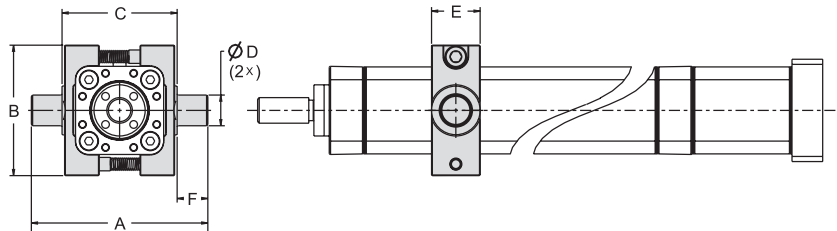

	A	B	C (h14)	D (Ø e9)	E	F (h14)	p/n
PC25	45	51	45	12	19	12	D607 427
PC32	74	65	50	12	25	12	D607 428
PC40	95	75	63	16	28	16	D607 429

### 4.8 Mounting of sensor brackets

The bracket can be installed over the left or right corner of the cover tube surface under which the sensor magnet travels. The correct cover tube surface is marked with a magnet sign sticker (1). The bracket (2) is secured using the worm drive clamp (3) that are put around the cover tube and the bracket. Make sure the clamp tightening screw is correctly positioned in the slot of the bracket.

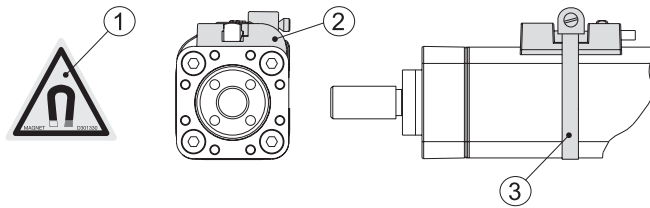

### 4.9 Mounting of sensors in the sensor brackets

The sensor is inserted in the slot of the sensor bracket and locked in to position by the clamp screw (1).



If the sensor is mounted in the immediate vicinity of magnetisable components, the switching characteristics of the sensor may change.

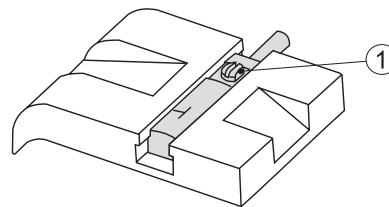

### 4.10 Motor installation on inline style actuators without RediMount system

The motor installation on a PC-Series actuator without a RediMount flange require either a suitable bell house type of flange and a coupling or a gearbox to be mounted between the motor and the actuator. The flange dimensions for each actuator size can be found in the table below. Make sure that the maximum permissible drive shaft force and torque are not exceeded (see table T6.1.1.) at any time during stand still or operation.

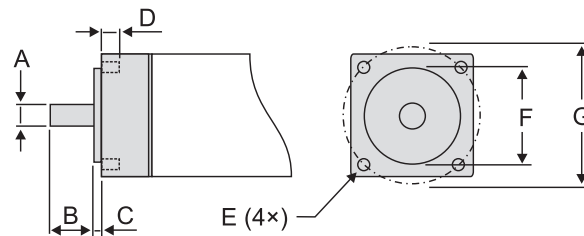

	A	B	C	D	E	F	G
PC25	6	14.5	2.5	44	M4	24	27
PC32	8	16.5	2.5	44	M6	32,5	34
PC40	12	18.6	2.4	44	M6	38	41

### 4.11 Motor installation on actuators with RediMount system

The motor installation on a PC-Series actuator with a RediMount flange require a suitable motor for the RediMount flange type the actuator in question is equipped with. Follow point 4.11.1 or 4.11.2 during installation depending on if the actuator are of inline or parallel style. Make sure that the maximum permissible drive shaft force and torque are not exceeded (see table T6.1.1.) at any time during stand still or operation. For removal of a motor see point 4.11.3.

## 4.11.1 Motor installation on inline style models with RediMount system

1. Make sure the extension tube is fully retracted and then remove the sealing plug.

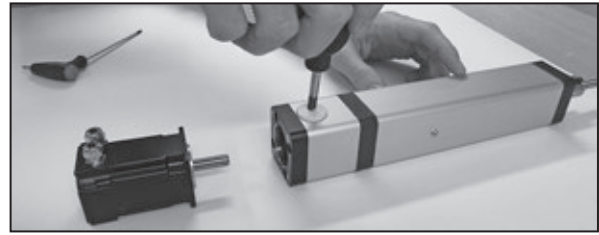

2. Press the motor shaft on to the coupling inside of the flange.

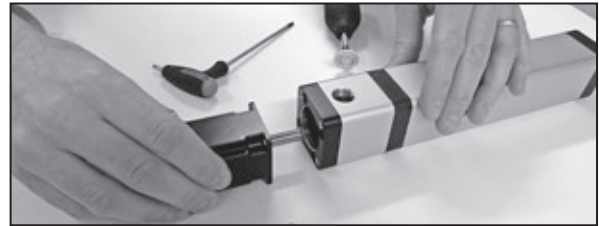

3. Bolt the motor to the flange using four screws. Tighten the screws according to table T6.3.1.



4. Use a hexagon key to tighten the coupling around the motor shaft. Correct tightening torque for:  
PC25 models = 0.85 Nm  
PC32 models = 2.0 Nm  
PC40 models = 2.0 Nm.

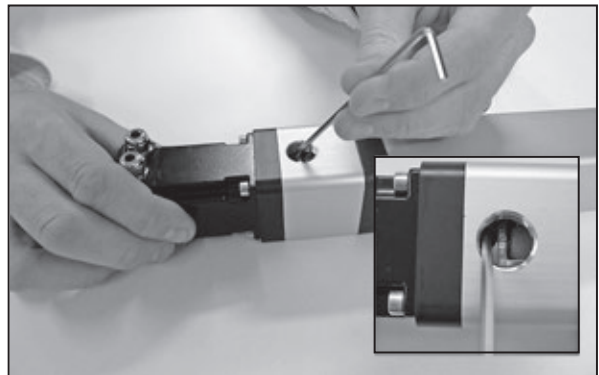

5. Put the sealing plug back.

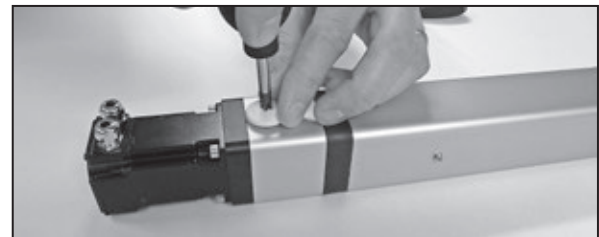

#### 4.11.2 Motor installation on parallel style models with RediMount system

1. Make sure the extension tube is fully retracted and then remove the sealing plug.

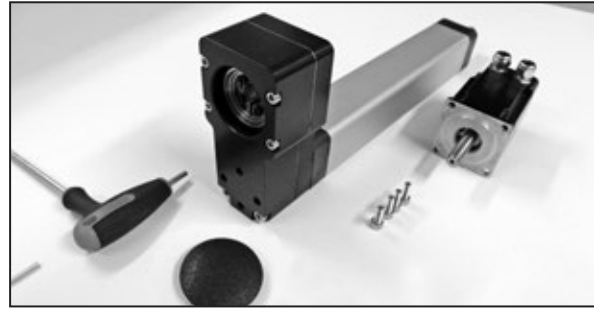

2. Press the motor shaft on to the coupling inside of the belt gear flange.



3. Use a hexagon key to tighten the coupling around the motor shaft. Correct tightening torque for:  
 PC25 models = 1.2 Nm  
 PC32 models = 2.1 Nm  
 PC40 models = 4.9 Nm.



4. Bolt the motor to the flange using four screws. Tighten the screws according to table T6.3.1.



5. Put the sealing plug back.



#### 4.11.3 Removal of motor from a unit with RediMount system

If removing a motor from a unit with RediMount system the extension tube must be fully extended to make it possible to loosen the coupling.

## 5. Service and maintenance

### 5.1 General

Regularly perform ocular control of the PC-Series unit and the installation it is a part of and service and repair if needed. If in doubt, please contact Thomson for advice.

### 5.2 Cleaning

The PC-Series actuators are designed to withstand water wash down. If the actuator needs to be cleaned, clean it gently and do not use any tools that mechanically can damage the actuator. If detergents are to be used during cleaning it is recommended to stay within pH 3.5 – 8.5.

### 5.3 Lubrication

Lubrication is needed after 600 hours of operation or 6 months depending on which happens first. Perform lubrication as described below.

1. Make sure the extension tube is fully retracted to the mechanical end position. Retraction to the mechanical end position may only be done if the actuator is unloaded and the retraction motion may not exceed the maximum torque and speed listed in table T5.3.1. Failing to do so may damage the actuator. Once in the mechanical end position the retraction must be stopped immediately.

T5.3.1 - Max. retraction torque and speed		
Model	Max. torque [Nm]	Max. speed [m/s]
PC25	0.25	0.25
PC32	0.25	0.25
PC40	0.50	0.25

2. Lubricate via the grease port (1) with a grease gun (nipple type DIN3405 D1/A) using a grease of type Urethyn E/M1 (semi-synthetic, high temperature grease containing an organic thickener) with the amount listed in T5.3.2.

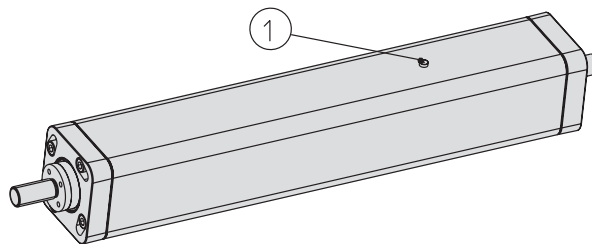

T5.3.2 - Grease amount and type		
Model	Grease Amount [cm <sup>3</sup> /10 cm stroke]	Grease type
PC25	0.75	Urethyn E/M1
PC32	0.75	
PC40	1.00	

## 5.4 Replacement of coupling on inline models with RediMount flange

The coupling may break at overload in which case it can be replaced per the instructions below. Make sure when replacing a broken coupling that all other components are intact.

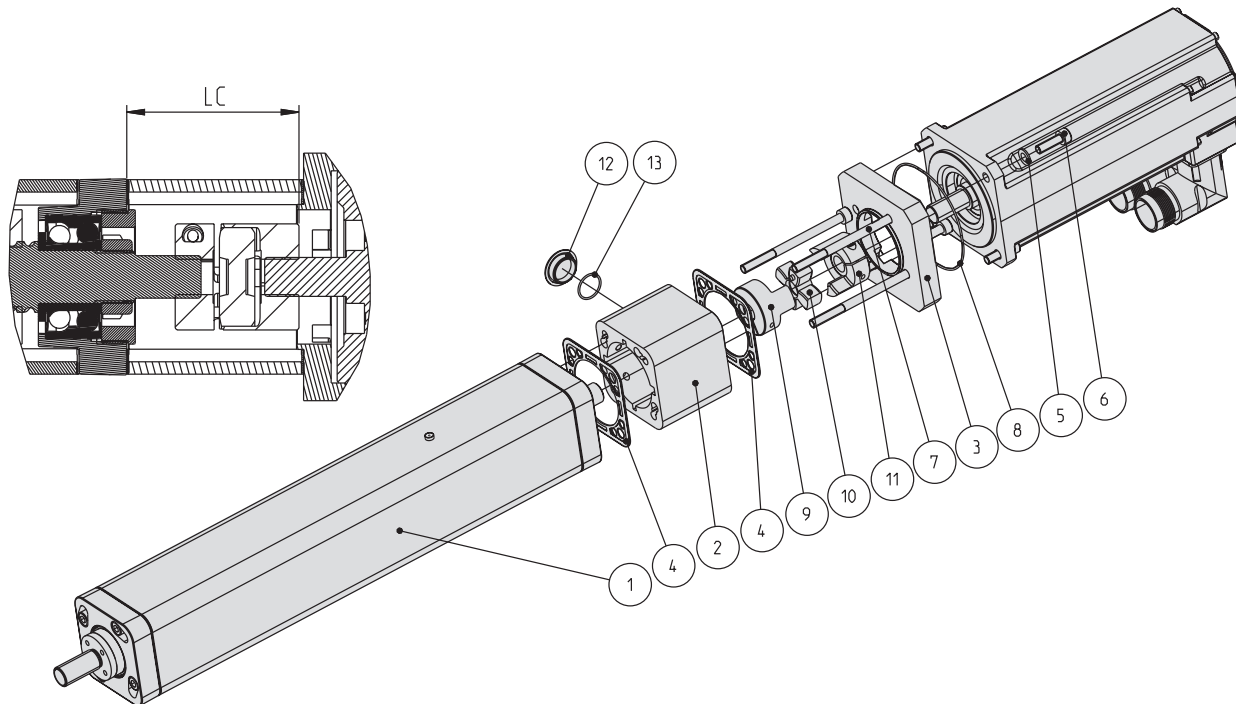

1. Remove cover lid (12) and loosen screws on the coupling half (11) closest to the motor and remove it.
2. Remove screws (6) and remove the motor.
3. Make sure the extension tube on the unit (1) is fully retracted (this may not be changed until the screws (7) are tightened again).
4. Remove screws (7) and the flange plate (3), the sealings (4) and the bell house (2).
5. Loosen the lock screw on the coupling half closest to the unit (9) and remove it.
6. Push on the new coupling and make sure the parts of the new coupling (9, 10 and 11) are fully pressed together.
7. Make sure the coupling are at the correct LC distance as listed in table T5.4.1.
8. Tighten the lock screw on coupling half as listed in table T5.4.2.
9. Make sure the sealing (4) is correctly positioned against the bell house (2) and the flange plate (3) before tightening screws (7) according to table T6.3.1
10. Mount the motor and tighten screws (6) according to table T5.4.2.
11. Tighten the lock screw on coupling half (11) according to table.
12. Check so that the o-ring (12) is not damaged, in which case it should be replaced, and put back the cover lid (12).
13. Test run the unit without any load 2 - 3 cycles to see that it runs smoothly and without any noise.

T5.4.1 - Distance LC	
Model	LC [mm]
PC25	10.0
PC32	7.0
PC40	14.0

T5.4.2 - Coupling half lock screw tightening torque	
Model	Nm
PC25	0.85
PC32	2.00
PC40	2.00

## 5.5 Replacement of belt gear timing belt

The belt may break at overload in which case it can be replaced per the instructions bellow. Make sure when replacing a broken belt that all other components are intact.

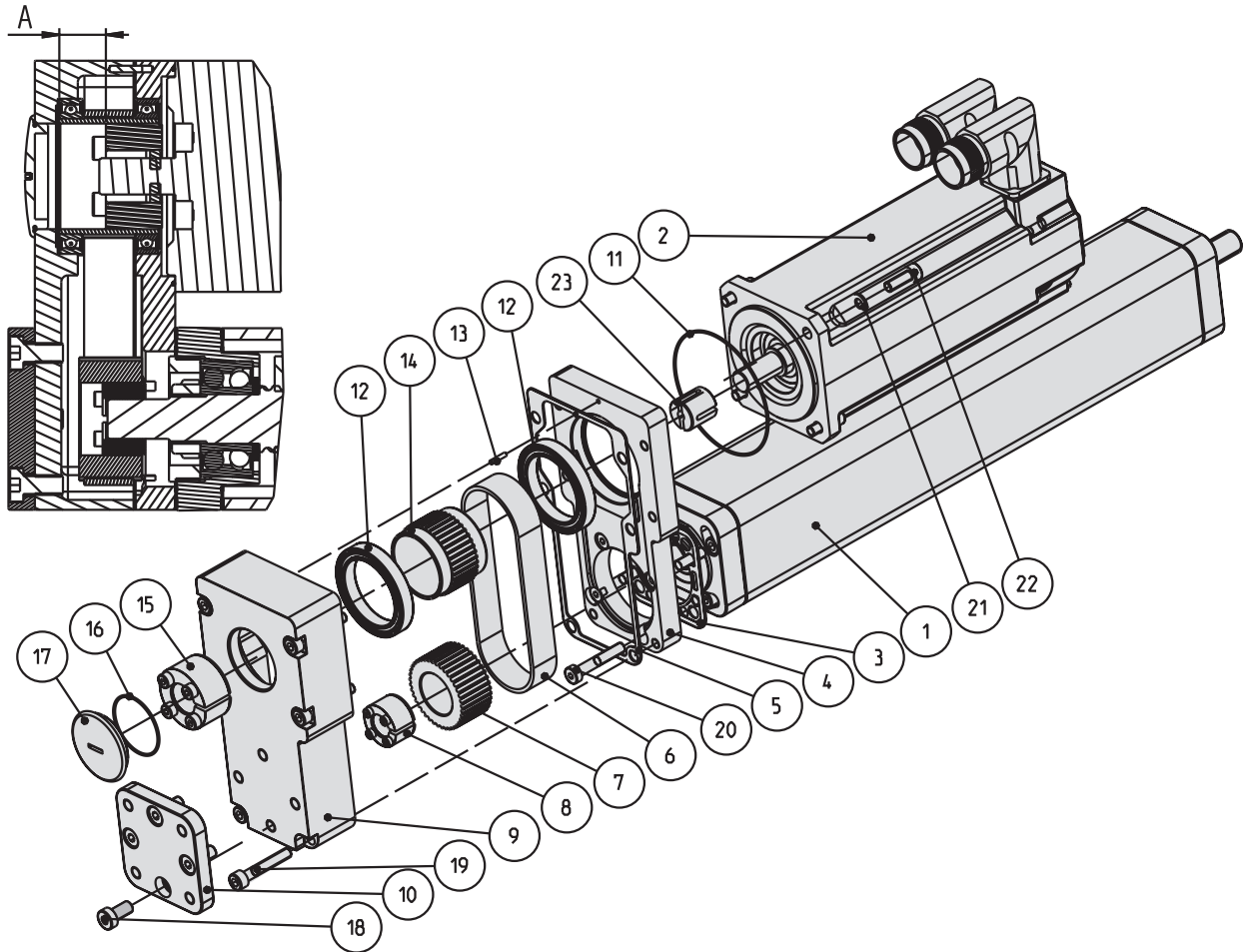

T5.5.1 - Screw size and tightening torque			
Model	Screw in position	Number of screws and sizes	Tightening torque [Nm]
PC25	18	4 × M5	6.50
	19	2 × M4	3.30
		4 × M3	1.35
PC32	20	2 × M4	3.30
	18	4 × M6	11.10
	19	6 × M4	3.30
PC40	20	4 × M4	3.30
	18	4 × M6	11.10
	19	6 × M5	6.50
	20	4 × M5	6.50

1. Remove cover lid (17) and loosen the lock screws on the coupling clamping unit (15).
2. Remove screws (21) and washers (22) and remove the motor (2).
3. Remove screws (18) and remove the plate (10).
4. Remove screws (19) and carefully remove the rear belt gear housing (9).
5. Check so that belt wheel (14) and its bearing (12) is attached to the front belt gear housing and loosen screw (20).
6. Pull out the PC-Series unit (1) 5 mm from the rear housing and replace the belt (6).
7. Push the unit (1) on to the housing again and tighten screw (20) according to table T5.5.1.
8. Put back the front housing (9) and make sure pin (13) and the belt wheel (14) with its bearing (12) gets correctly positioned.
9. Mount screws (19) and tighten them according to table T5.5.1.
10. Mount plate (10) and tighten screws (18) med according to table T5.5.1.
11. Mount the motor (2) and make sure it is correctly aligned to the coupling clamping unit (15) and its sleeve (23) before tightening screws (22).
12. Make sure the coupling clamping unit (15) is positioned correctly at distance A (see table T5.5.2) from the upper edge of the bearing and that the sleeve (23) is inside of the clamping unit (15).

T5.5.2 - Distance A	
Model	A [mm]
PC25	10.0
PC32	7.0
PC40	14.0

13. Pre-tighten the clamping unit lock screws (15) and then tighten them cross wise until all have the correct tightening torque according to table T5.5.3.

T5.5.3 - Coupling clamping unit screw tightening torque	
Model	Nm
PC25	1.2
PC32	2.1
PC40	4.9

14. Check so that the o-ring (16) is not damaged, in which case it should be replaced, and put back the cover lid (17).
15. Test run the unit without any load 2 - 3 cycles to see that it runs smoothly and without any noise.

## 6. Technical Specifications

### 6.1 Technical data

T6.1.1 - Technical Specifications <sup>(1)</sup>				
		PC25	PC32	PC40
Profile size (w × h)	[mm]	34 × 34	45 × 45	55 × 55
Linear speed, maximum	[m/s]	1.33	1.00	1.66
Acceleration, maximum	[m/s <sup>2</sup> ]	10	10	10
Repeatability	[± mm]	0.01	0.01	0.01
Input speed, maximum	[rpm]	8000	6000	5000
Operation temperature limits	[°C]	-20 – +70	-20 – +70	-20 – +70
Dynamic load (Fx), maximum	[N]	1250	3200	6000
Dynamic load (Fy), maximum	[N]	20	20	50
Dynamic load (Fz), maximum	[N]	20	20	50
Dynamic load torque (Mz, My), maximum	[Nm]	10	25	25
Drive shaft force (Frd), maximum	[N]	100	300	650
Input torque, maximum	[Nm]	2.3	5.1	5.8
Drive shaft torque (Mta), maximum	[Nm]	4.0	9.2	24
Weight of unit, inline style without RediMount	[kg]	0.417 + (S [mm] × 0.0021)	0.629 + (S [mm] × 0.0034)	1.463 + (S [mm] × 0.0052)
Weight of unit, inline style with RediMount	[kg]	0.543 + (S [mm] × 0.0021)	0.893 + (S [mm] × 0.0034)	1.853 + (S [mm] × 0.0052)
Weight of unit, parallel style	[kg]	0.778 + (S [mm] × 0.0021)	1.221 + (S [mm] × 0.0034)	2.318 + (S [mm] × 0.0052)
Type of screw		ball screw	ball screw	ball screw
Protection class		IP65	IP65	IP65

(1) Specifications are subject to change without notice. It is the responsibility of the product user to determine the suitability of this product for a specific application.

#### 6.1.1 Definition of forces

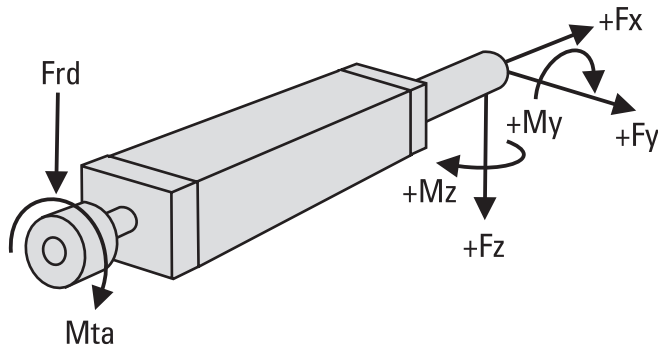

## 6.2 Ordering key

T6.2.1 - Ordering Key								
1	2	3	4	5	6	7	8	9
PC	25	LX	423	B10-	0270	M	J	1
<p>1. Actuator type PC = PC-Series precision linear actuator</p> <p>2. Size 25 = profile size 34 × 34 mm 32 = profile size 45 × 45 mm 40 = profile size 55 × 55 mm</p> <p>3. Transmission type SX = inline style, directly coupled, no RediMount flange LX = inline style, directly coupled, RediMount flange PA = parallel style, 1:1 belt gear in standard position</p> <p>4. RediMount motor ID 000 – 999 = code for flange XXX = code used when unit has no RediMount flange.</p> <p>5. Screw type and lead B03- = ball screw, 3 mm lead B04- = ball screw, 4 mm lead B05- = ball screw, 5 mm lead B10- = ball screw, 10 mm lead B20- = ball screw, 20 mm lead</p>				<p>6. Stroke length (S max) 0000 – 9999 = distance in mm</p> <p>7. Cylinder mounting R = rear trunnion (fixed, mounted on belt gear) C = rear clevis F = feet kit M = trunnion (movable) T = front trunnion (fixed, mounted on front housing) P = front mounting plate X = without any cylinder mounting</p> <p>8. Rod end M = male thread (standard) F = female thread J = spherical joint C = front clevis</p> <p>9. Environmental 1 = IP65 rating (standard)</p>				

## 6.3 Screw tightening torque

T6.3.1 - Screw tightening torque	
Screw size	Tightening torque [Nm]
M3	1.35
M4	3.30
M5	6.50
M6	11.10

Contact us or any of our 2000+ global distribution partners by scanning the code below  
or visiting [www.thomsonlinear.com/contact](http://www.thomsonlinear.com/contact)



**RegalRexnord™**

[www.regalrexnord.com](http://www.regalrexnord.com)

[www.thomsonlinear.com](http://www.thomsonlinear.com)

PC\_Series\_Installation\_Operation\_MNEN-0023-03 | 20251125TJ  
Specifications are subject to change without notice. It is the responsibility of the product user to determine the suitability of this product for a specific application. All trademarks property of their respective owners. ©2025 Thomson Industries, Inc. | 2400 Curtiss Street, Downers Grove, IL 60515 USA

**THOMSON®**